

Grand Design of Electronic CP Settlement System

Appendix

- A. Terminology
- B. Current Settlement System



Appendix A.

Terminology

(Note)

This appendix provides the meanings of various terms used in this report. It should be noted that this appendix does not necessarily explain the general meanings.



A. Terminology

A

Account Manager Institution A participant of the Central Depository who has opened an account for other companies' trade settlement, when Multiple Levels of Accounts are introduced by the revision of the Electronic CP Law.

B

BOJ the Bank of Japan, the central bank of Japan

BOJ NET BOJ's fund and JGB settlement system. Only selected financial institutions can open current accounts with BOJ for fund settlement and/or JGB settlement. BOJ NET provides its participants with Toroku (registered) and Furiketsu (Book Entry Transfer) JGB settlement functions.

C

Clearing Bank A bank managing a deposit account of an issuer or investor. Upon an instruction from the client, the bank settles the money transfer. In the SSI of the Central Depository each participant's clearing bank and account(s) are recorded. A participant having both accounts can settle a JGB trade DVP. A participant of only the JGB system needs to entrust another participant to settle funds for DVP.

CPU Interface a method of exchanging data for trade settlement between a participant and the Central Depository. This directly connects a participant's computer system to the Central Depository's system, and the data is transferred on a real time basis. Although it is costly to develop an interface between the systems, especially at the initial stage, it allows a large volume of data to be processed at an instance.



A. Terminology

C

CD Central Depository - Central Clearing/Depository Institution for securities.
In the Electronic CP Law, it refers to a 'Transfer Institution' (especially under the Multiple Levels of Accounts Scheme)

D

Dealer a Financial Institution underwriting and trading Electronic CP in this report (Dealers may hold Electronic CP as an investor)

DVP Delivery Versus Payment.
Simultaneous settlements of funds and securities. This is a requirement to reduce settlement exposures to a settlement system.

E

Electronic CP CP defined by the Law concerning Transfer of Short Term Corporate Note, etc. which was approved by the Diet in June 2001. Un-certificated and electronically tradable CP. A word to separate it from the usual Promissory Note Form of CP.

Electronic CP Law The so-called Electronic CP Law, officially the Law concerning Transfer of Short Term Corporate Notes, etc. It will be revised in the Ordinary Session of the Diet in 2002, be renamed the Corporate Bond Transfer Law and will be the core law for Japanese securities settlement systems.

Electronic Bond Law The so-called Electronic CP Law will be revised to cover not only CP but also other fixed income products and renamed the Corporate Bond Transfer Law. It will be called Electronic Bond Law for short.



A. Terminology

F

Furiketsu JGB Furiketsu is the Japanese abbreviation of Furikae Kessai meaning Book Entry Transfer. In BOJ NET, BOJ provides the system participants with the book entry transfer function. The registered name is BOJ in the Toroku JGB system. The JGB is called a Furiketsu JGB.

G

GSTPA Global Straight Through Processing Association
An organization established by asset management companies, securities companies, and custodians in order to make cross-border transaction settlement flow more efficient and it aims to promote STP globally

I

Instruction with Message A BOJ NET fund transfer instruction having a message column prepared for a special purpose. In this report we suggest that the message column be used for a special instruction. Currently, the message column is used for JGB trade settlement and we assume that the column should be usable for electronic CP settlement. (Note. In the original Japanese, a term, "Telegraph", is used for the BOJ NET settlement instruction. When translating to English, the word was all replaced with "Instruction".)

Inter Bank Market Markets where only some limited financial institutions can partake, such as the Call Market, Bill Market, etc.

IPA Issuing and Paying Agent
A general term for the Issuing Agent (a financial institution that carries out the necessary tasks for an issuance on behalf of the Issuer) and Paying Agent (a financial institution that handles coupon / redemption payments on behalf of the Issuer). In Europe/US, it is normal to designate an IPA at CP issuance.



A. Terminology

I

ISIN Code	International Security Identification Number Code. International security codes. An assigned security code with 12 digits defined by ISO6166
Issuer	a corporation which issues Electronic CP / Electronic Bonds.
ITC DVP	DVP function with simultaneous collateral deposit (bought) or withdrawal (sold) in BOJ NET JGB RTGS DVP Settlement. BOJ calls the function ITC (in-transit collateral) DVP. In the case of a buy, the receivable security is deemed as a collateral deposit for the BOJ's intra-day liquidity supply (intra-day OD) for the purchase. In the case of a sell, the receivable trade proceeds are regarded as a repayment of intra-day OD and JGBs being deposited as collateral can be simultaneously withdrawn to deliver for the sale.

J

JASDEC	Japan Securities Depository Center. Central clearing/depository institution for equities in Japan. It is currently a foundation but will be dissolved after April, 2002. In its place, New JASDEC will be established as a joint stock corporation. It is expected to expand the product coverage by the revision of related laws.
JASDEC Law	The so-called JASDEC Law. Officially, it is the Law concerning Custody and Transfer of Equities. Etc. Together with the revision of the Electronic CP Law (renamed as the Corporate Bond Transfer Law), it will be amended to allow JASDEC to be a central depository for other products.
JGB	Japanese Government Bond



A. Terminology

J

JSDA Japan Securities Dealers Association. Self-regulatory body of the Japanese securities industry.

M

Matching Before a trade is settled, both parties reconcile their trade contents. It is called matching here. It is especially used in automatic reconciliation by the central depository.

Multiple Levels of Accounts In such a system the A/C ledger of the electronic CP Beneficial owner is managed by an A/C Manager Institution and the A/C ledger of the A/C Manager Institution is managed by the Central Depository. The Central Depository only has to manage participants' accounts. The beneficial owners' positions are managed only by an A/C Manager Institution.

O

Omgeo a company jointly established by Depository Trust & Clearing Corporation (DTCC) and Thomson Financial, providing trade management services, such as trade settlement details matching/confirm, etc., and aiming for T+0 settlement of cross-border transactions.

Open Market A market which is open not only to some limited financial institutions but also to others, such as the CP Market, Repo Market, etc.

P

Pay-off Partial Deposit Insurance Scheme. When a financial institution goes bankrupt, the customer's asset with the bankrupt institution are insured but only up to JPY 10 million.



A. Terminology

Q

- Quasi Escrow** Modelled on bank's Escrow, the Central Depository has participants pay subscription moneys to the Central Depository's deposit account (quasi escrow A/C) on electronic CP issuance and then transfers the funds to the Issuer upon completion of the new registration of the CP. (Escrow: an intermediate service provided by a bank in order to avoid the case where a seller of a product cannot receive funds or a buyer cannot receive the purchased product (normally a service to the seller)).
- Queuing** Putting settlement instructions into a Queue waiting for settlement. In the Grand Design of the new settlement system, it is planned, making use of the Queue, to retry an instruction which has failed once and sort the instructions to raise the efficiency of settlement.

R

- RTGS** Real Time Gross Settlement
A settlement method of a central bank's current account settlement system of carrying out each instruction immediately after the instruction comes in. On the other hand, the method of carrying out all received instructions at a pre-determined time is called Jiten Kessai. As settlement is done instruction by instruction, there is less risk of a failed trade affecting parties other than those involved in the failed trade itself (Systemic Risk).

S

- Single Level of Accounts** A system that the Transfer Institution (Central Depository, CD) has to manage all beneficial owners' account ledgers. Under the current Electronic CP Law it is a requirement for all CP holders to be participants of the CD which manages all holders' accounts. In such a case, the CD's operational burdens increase significantly as all transfers are handled in the CD.



A. Terminology

S

SSI	<p>Standing Settlement Instruction</p> <p>Once all participants register their SSI with the Central Depository, it is not necessary to confirm sec. account, fund account, etc. each time for trade settlement.</p>
STP	<p>Straight Through Processing</p> <p>In order to shorten the settlement cycle, make operations more efficient, and reduce costs, STP aims to deal with all trade related data with as little manual work as possible after a trade is executed. For the realization of STP, system connection and standardization of operational procedures are necessary.</p>

T

T+0	<p>(Trade date)+0 Settlement. Settlement of a trade on the same day as the trade date. In the US and France, CP is settled on T/D.</p>
Terminal Linkage	<p>A participant of the Central Depository (CD) sends an instruction through the CD System terminal provided by the CD and is able to inquire about the status/result through the terminal. As a participant only has to install the terminal, the cost is cheap. However, it is rather difficult to deal with many trades in a limited time frame.</p>
Toroku JGB	<p>Registered JGB. BOJ is the registration agent for JGBs. The central bank provides Toroku JGB transfer and registration services. Some part of Toroku JGBs are registered in the name of BOJ and BOJ provides Furiketsu participants with book entry transfer and custody services (Furiketsu JGB).</p>



A. Terminology

T

TFM	Transaction Flow Manager A centralized matching system for the realization of T+0 settlement of cross-border transactions. (axion4 develops and manages the system). The pilot test is to be conducted in late 2001 and it will then commence operation.
Transfer Institution	An institution which provides services for electronic CP transfers under the Electronic CP Law. Accounts are managed by the institution. In the Grand Design, we planned that the institution not only has the account management function but also settlement detail matching and DVP functions. (Note. If the originally used Japanese term is translated to English, it is 'Transfer Institution'. However, as this does not seem to describe the nature/functions of the institution, in this report the term, in principle, was translated as 'Central Depository'.)

W

Whole Amount Underwriter	A dealer or an Investor not underwriting a part of issued bond, etc. but the whole amount of an issued bond. On the other hand, it is called 'standby underwriting' to underwrite the remaining part unsold after the offering of the bond. In the case of Electronic CP, we assume only the Whole Amount Underwriting method.
--------------------------	--

Z

Zengin System	Inter-bank fund transfer system provided by Zengin-kyo (the Federation of Banking Associations)
---------------	---



Appendix B.

Current Settlement Systems

- B - 1. Summary of Current Systems
- B - 2. JGB Book Entry Transfer System
(Furiketsu JGB)
- B - 3. Japan Bond Settlement Network (JB NET)
- B - 4. TSE (Tokyo Stock Exchange) DVP
- B - 5. CP Settlement System (Pilot System)

B - 1. Summary of Current Systems (1/5)

	JGB Settlement (BOJ NET JGB System)	Corporate Bond Settlement (JB NET / Registration Agent)	Equity Settlement (JASDEC / TSE DVP)	CP Settlement (CP Pilot System)
Systems Operator	BOJ (the Bank of Japan)	JB NET (Japan Bond Settlement Network) and about 40 Registration Agents	JASDEC (Japan Securities Depository Center)	
Number of Participants	About 400 users (including direct and indirect participants)	Users: about 500 direct participants (including 226 non-online participants) and about 300 indirect participants (via custodians) Pre-Settlement Service Agents (Registration Agents): about 40 companies	About 300 companies	Under Pilot Test: 2 investors, 2 dealers, 2 issuing companies, 1 issuance/paying agent, and 2 clearing banks
Indirect Participant	Yes (including Foreign Indirect Participant)	Yes (only when the counterparty of a trade is a direct participant)	Yes (participation by non-securities companies as special participants)	Yes
Agent Participation		Yes (allows Custodian to handle)	Yes (allows Securities Agent to act as agent)	Yes
Eligible Products	Government Bonds issued by the Japanese Government (JGBs: including Treasury Bills and Finance Bills)	General bonds other than JGBs	Domestically issued stocks with issuing companies' agreement and Tonto Registered (JASDAQ) stocks	Electronic CP (discount type)

B - 1. Summary of Current Systems (2/5)

		JGB Settlement (BOJ NET JGB System)	Corporate Bond Settlement (JB NET / Registration Agent)	Equity Settlement (JASDEC / TSE DVP)	CP Settlement (CP Pilot System)
Operation	Issuance		(Initial Registration)	x	
	Trading		(Registration Change)		
	Coupon/Dividend		x	x	x
	Redemption		x	x	
Security Settlement Method		Book Entry Transfer in BOJ NET	Transfer in Register Book at Registration Agent	Book Entry Transfer in the relevant system	Ownership Transfer Record in the Register Ledger of the system
Settlement Date		T+3	T+3 at the shortest	T+3	T+0 (Redeemable on Gensaki End S/D)
Fund Settlement Method		With linkage to BOJ NET Current Account Settlement System	At BOJ NET Current A/C System	At designated Clearing Banks (including BOJ)	Via Fund Settlement Center (Pilot System): BOJ NET / Zengin System / Internal Transfer, etc. are planned

B - 1. Summary of Current System (3/5)

		JGB Settlement (BOJ NET JGB System)	Corporate Bond Settlement (JB NET / Registration Agent)	Equity Settlement (JASDEC System: TSE DVP)	CP Settlement (CP Pilot System)
DVP Scheme	Model	Gross (Security) = Gross (Fund)	Gross = Net (Funds settle at 3:00 PM, once a day (Jiten Kessai: pre-determined Timing Settlement) / Sec. transfers at Registration Agent after Fund Settlement is completed)	Net = Net (Funds settle - payable or receivable / Security is settled by issue)	Gross = Gross
	Unit (quantity)	Trade Quantity	Trade Quantity (but only for registration change with DVP)	By participant (through Net-Debit Calculation Process, for delivered shares and cash collateral paid, receivable shares are given)	Trade Quantity
	Fail Measure	Handled outside the system	Handled outside the system	Failed trades are managed by TSE System. It is carried forward to the following business day and netted with other trades on the day following S/D	The parties concerned are informed of the fail. They need to instruct the Network Center to retry or cancel it. In case of cancellation, the subsequent related trades are also cancelled.
Realization of RTGS			×	×	×

B - 1. Summary of Current System (4/5)

		JGB Settlement (BOJ NET JGB System)	Corporate Bond Settlement (JB NET / Registration Agent)	Equity Settlement (JASDEC / TSE DVP)	CP Settlement (CP Pilot System)
Clearing	Security Netting	×	× (gross settlement by trade)	(by Issue)	×
	Fund Netting	×	Actually netted through the BOJ Current A/C System 3:00 PM Jiten Kessai Process	(by Member)	×
Risk Control	Intra-Day Liquidity Supply	JGB DVP Simultaneous Collateral Deposit/Withdrawal Function (ITC DVP)	×	Net - Debit Calculation Process and Cash Collateral Deposit on the same S/D	× (depending on each clearing bank's system)
	Grid Lock Solution Measure	×	Balance Check / Loop Check by Registration Agent	×	×
	Account Levels	Yes (Basic Accounts [principal/ customer accounts] and Supplemental Accounts [coupon payment account])	Yes (classify: Finance A/C and Other A/C)	Yes (by codes of Trust Asset A/C, Collateral A/C, Custodian A/C, etc)	No (a participant can open multiple accounts and can manage them by himself)
	MGT of Room for Settlement Availability	Confirm by participant's inquiry (short balance will result in error)	Security: Registration Agent checks / Fund: via BOJ Net Current A/C System	Understand by repeating Net-Debit Calculation Process several times	Manage the S/D ownership position (inquiry by Trade Confirm Function, etc.)

B - 1. Summary of Current System (5/5)

	JGB Settlement (BOJ NET JGB System)	Corporate Bond Settlement (JB NET / Registration Agent)	Equity Settlement (JASDEC / TSE DVP)	CP Settlement (CP Pilot System)
Settlement Confirm/Matching Infrastructure	(Counterparty checks Settlement Advice)	As a supplemental measure, MAC (Message Authentication Code) is exchanged between the parties concerned (MAC is entered in the settlement instruction)	(Usage of Settlement Confirm System)	System checks by Trade Confirm Function. Seller inputs and Buyer approves. Electronic Signature Authentication System.
Settlement Volume (no. of Trades - per day / one way)	about 8,870 trades on average	about 590 trades on average	about 86,000 trades on average (exchange trade settlement)	
Settlement Volume (Monetary Amount - per day / one way)	about JPY 30 trillion	about JPY 470 million	about 855 million shares (exchange trade settlement)	
Transfer Fee	about JPY 100 per transfer	JPY 1,125 per DVP transfer	JPY 10 per unit lot (exchange trade settlement)	



B - 2. JGB Book Entry Transfer System (Furiketsu JGB)

- B - 2 - 1. Overview of System
- B - 2 - 2. Timetable for Settlement
- B - 2 - 3. Account Management
- B - 2 - 4. Settlement Process

B - 2 - 1. Overview of System (1/2)

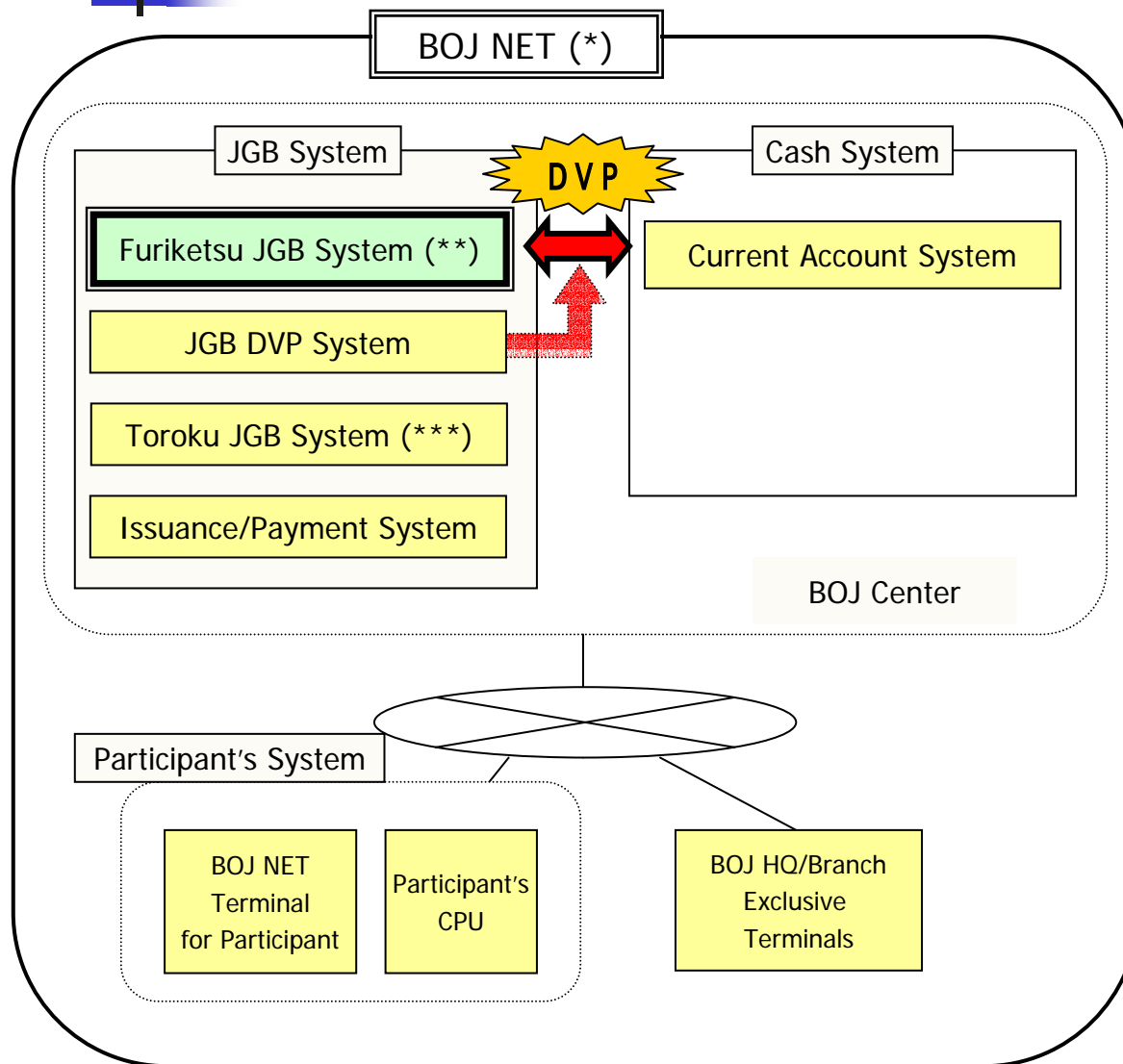

Furiketsu JGB System

JGB book entry transfers are settled in Furiketsu JGB system in BOJ NET JGB system. (Fund transfers are done in Current A/C Transaction System of BOJ NET. A JGB DVP settlement is done via JGB DVP system of BOJ NET JGB system with linkage between Furiketsu JGB and Current A/C systems.)

Participants (JGB System)

more than 400 (Oct. End, 2000)
(about 250 banks & 100 securities firms)

JGB Settlement Amount

186,179 trades (JPY 573.9 trillion) (in July, 2001)

(*)BOJ Net: Operation system of the Bank of Japan (BOJ). Including current a/c transaction system and JGB system.

(**) Furiketsu JGB: JGBs in the Book Entry Transfer System of BOJ NET. All are registered in the name of BOJ at Toroku JGB system. BOJ is the only bailee and provides book entry transfer and custody services for the holders. See the next page.

(***) Toroku JGB: Registered JGB. BOJ is the Registration Agent for JGB. See the next page.

B - 2 - 1. Overview of System (2/2)

The structure of BOJ NET Furiketsu JGB System is as follows:

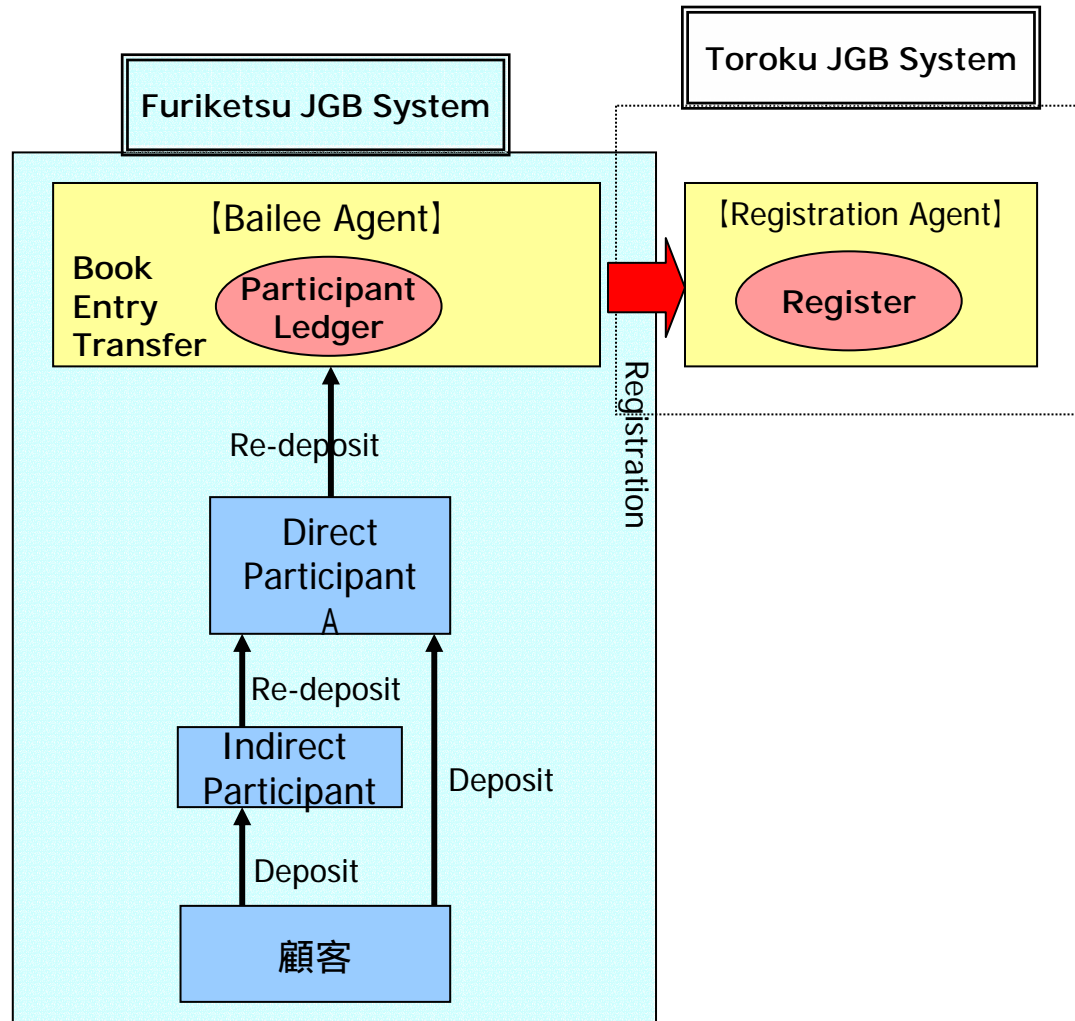

[Deposit / Re-deposit]

Client deposits JGBs with a direct or indirect participant of the Furiketsu JGB system following his trade or collateral obligation.
(when it is deposited with an indirect participant, it is re-deposited with a direct participant)

A direct participant deposits the JGBs received from the customer (indirect participant) together with the participant's own position with BOJ as Bailee Agent.

[Book Entry Transfer]

JGB settlement is done by book entry transfer in the participant's ledger at the Bailee Agent.

[Registration]

Bailee Agent registers the JGBs in its name in bulk in the Register at the Registration Agent.

B - 2 - 2. Timetable for Settlement

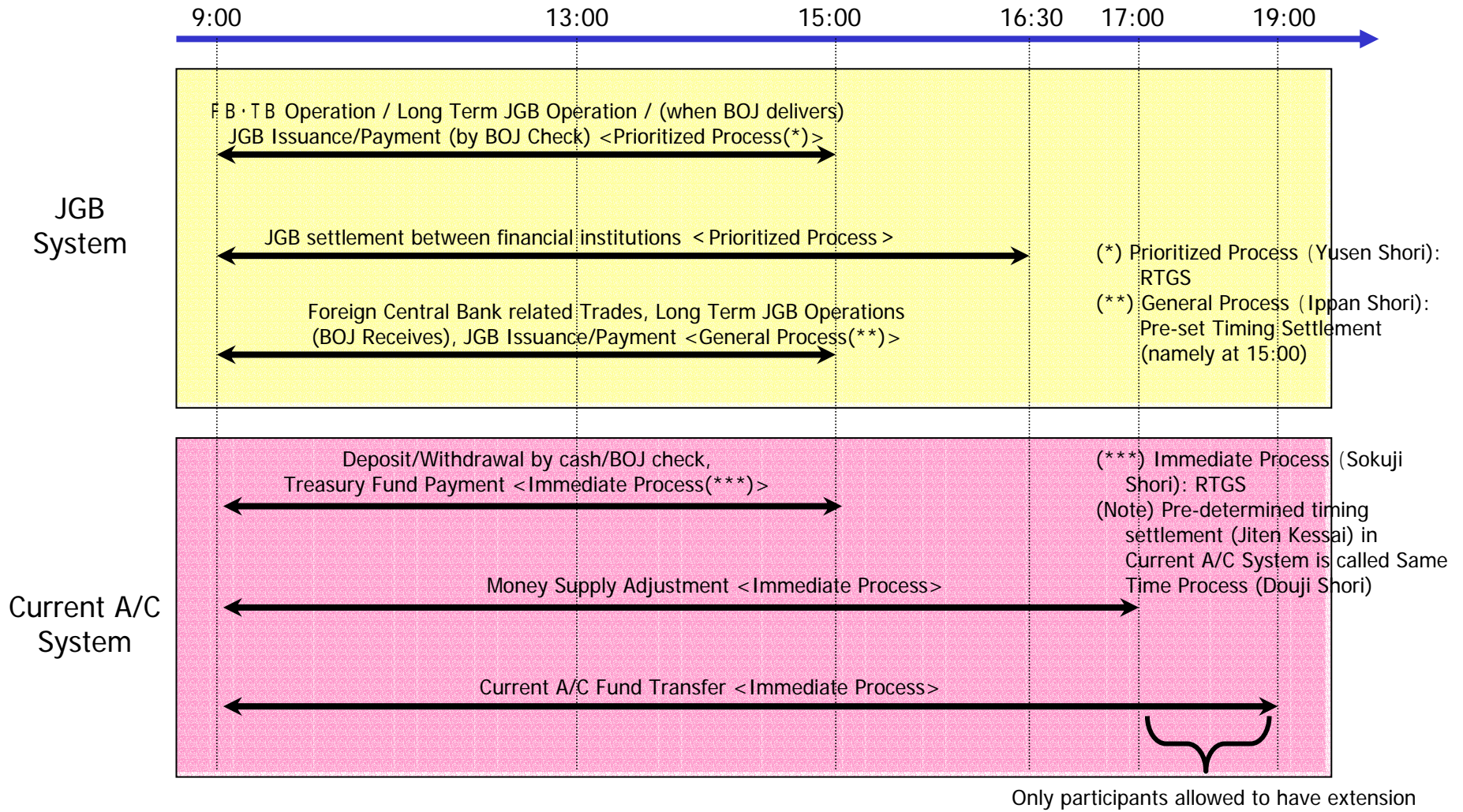

B - 2 - 3. Account Management

The A/C Structure of Furiketsu JGB at the Bailee Agent is as follows:

Basic Accounts	Principal Accounts	Principal A/C I ... Participant's own tax exempt position
		Principal A/C II ... Participant's own tax exempt position as pledgee
		Principal A/C III ... Participant's own taxable position
		Principal A/C IV ... Participant's own taxable position as pledgee
Customer Accounts	Customer A/C I ... Customer's deposited tax exempt position	
	Customer A/C II ... Individual Aged Exempt Customer's deposited position	
	Customer A/C III ... Customer's deposited taxable position	
Supplemental Accounts	Coupon Payment Accounts	Tax Exempt A/C ... Tax exempt positions subject to the next coupon payment are transferred to this account for a few days before the CPD to calculate the coupon interest amount.
		Taxable A/C ... Taxable positions subject to the next coupon payment are transferred to this account for a few days before the CPD to calculate the coupon interest amount.

B - 2 - 4. Settlement Process (1/4)

- Settlement Method

The settlement flow of a Furiketsu JGB Trade is as follows:
(A trade was executed between JGB Seller, A Bank, and JGB Buyer, B Securities,)

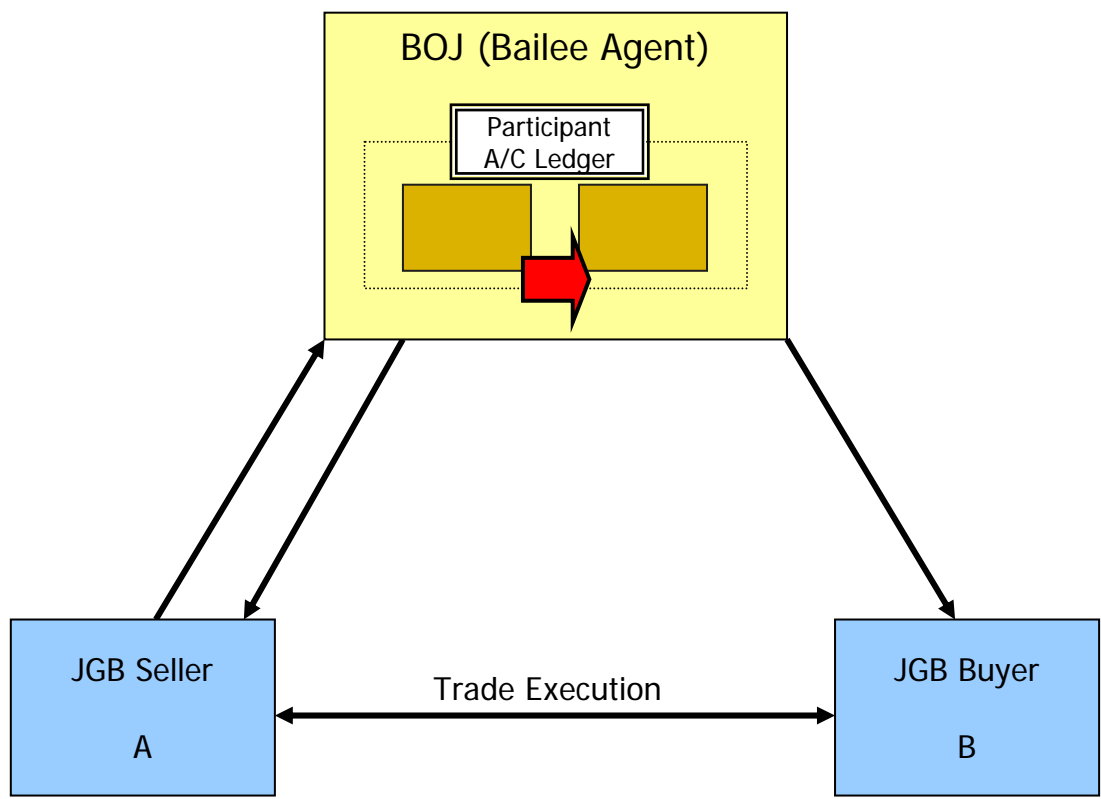

JGB Furiketsu Settlement Flow

After execution, Seller sends BOJ a delivery instruction.

BOJ sends the delivery instruction acceptance notice to Seller and the JGB delivery notice to Buyer.

In BOJ's Participant Ledger, JGB Position Transfer is completed.

B - 2 - 4. Settlement Process (2/4)

- DVP Scheme

The JGB Trade DVP Settlement Scheme is as follows:

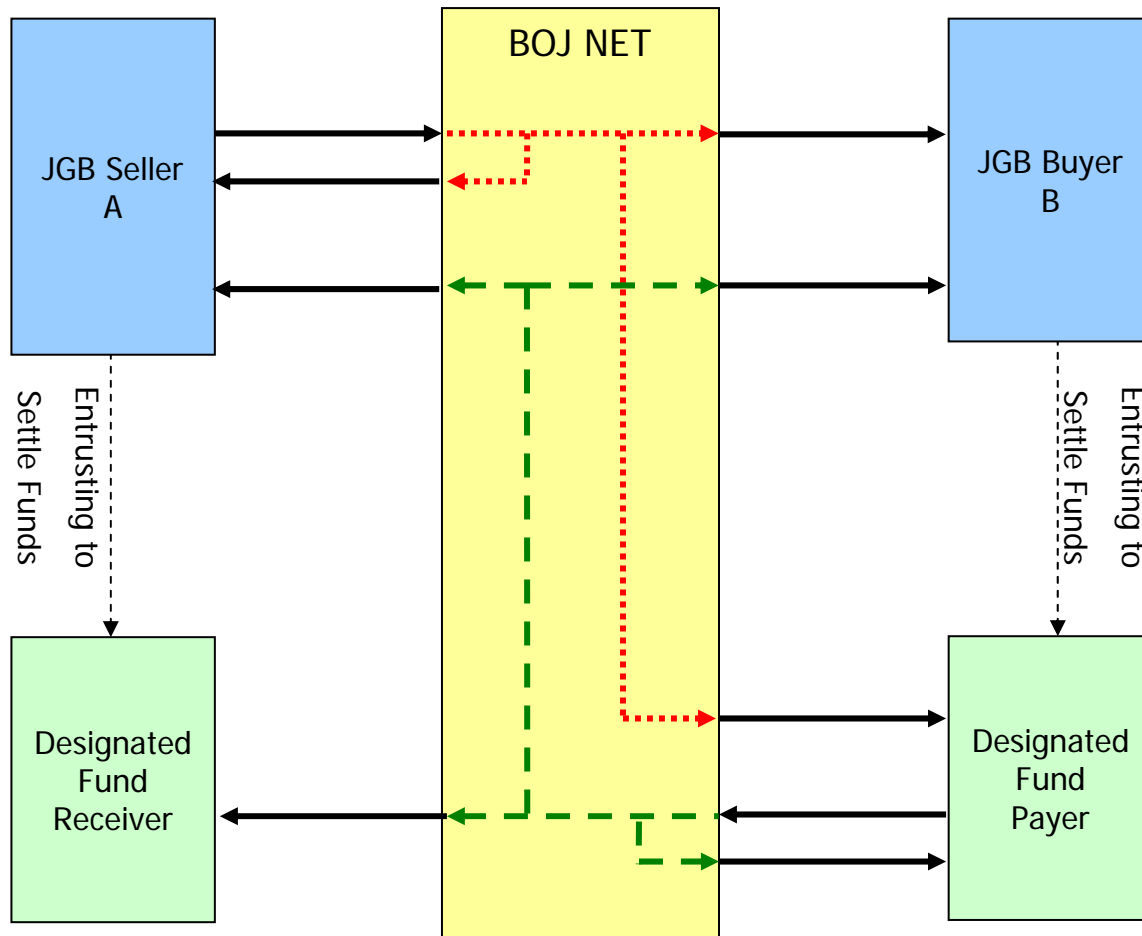

DVP Settlement Flow

JGB Seller sends JGB Delivery (DVP) Instruction to BOJ.

BOJ Sends Buyer the Advice of JGB Delivery (DVP) Instruction Received and sends Seller Notice of the Accepted JGB Delivery (DVP) Instruction.

BOJ sends Request of Fund Payment to the Fund Payer Participant designated by Buyer as Fund Settlement Agent

The Designated Fund Payer sends Payment Instruction to BOJ.

JGB Transfer / Fund Transfer take place simultaneously.

BOJ sends Seller's Designated Fund Receiver the Notice of Current A/C Credited and sends the Buyer's Designated Fund Payer the Accepted Payment Instruction.

BOJ sends notice of JGB DVP Settlement Completion to both Buyer and Seller.



B - 2 - 4. Settlement Process (3/4)

- RTGS Scheme

BOJ introduced RTGS not only for the Current Account Settlement System but also for the JGB Settlement System in BOJ NET with effect from 2001. It became possible for both funds and securities to be settled on a gross and real time basis: "GROSS = GROSS Type DVP" system. The scheme is as follows:

1. Settlement of JGB trades between market financial institutions is under the Prioritized Process (RTGS)
2. When BOJ delivers JGBs for BOJ Open Market Operation Trade Settlement of long term JGBs, etc., the settlement is under the Prioritized Process (RTGS)
3. However, in the following cases, for the time being the settlement is under the General Process (Jiten Kessai - Pre-determined Timing Settlement: Net Based)
 - When BOJ, as custodian of foreign central banks, settles their JGB trades
 - On-line payment for newly issued JGBs
 - When BOJ receives JGBs for Open Market Operation Trades of long term JGBs, etc.

At the introduction of RTGS, BOJ newly provided participants with the JGB DVP Simultaneous Collateral Movement Function (so-called ITC DVP). Refer to the following page for details.

B - 2 - 4. Settlement Process (4/4)

- ITC (In-Transit Collateral) DVP

(1) When receiving JGBs

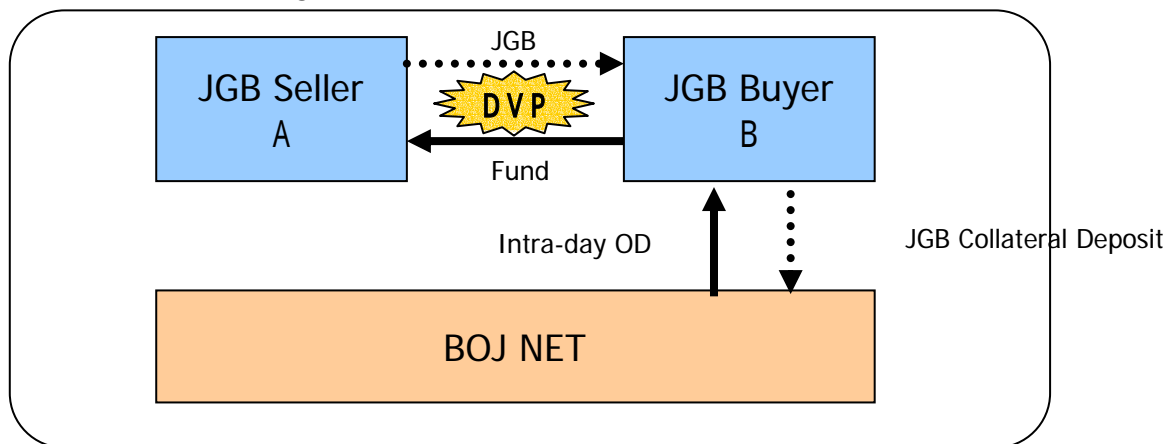

In order to smoothly settle JGB trades DVP, BOJ provides the JGB DVP Simultaneous Collateral Movement Function (so-called ITC DVP) - regarding the received JGBs as collateral, BOJ supplies intra-day liquidity (intra-day OD). The outline of the function is illustrated on the left.

(Explanations of the respective actions are on the following page)

(2) When delivering JGBs

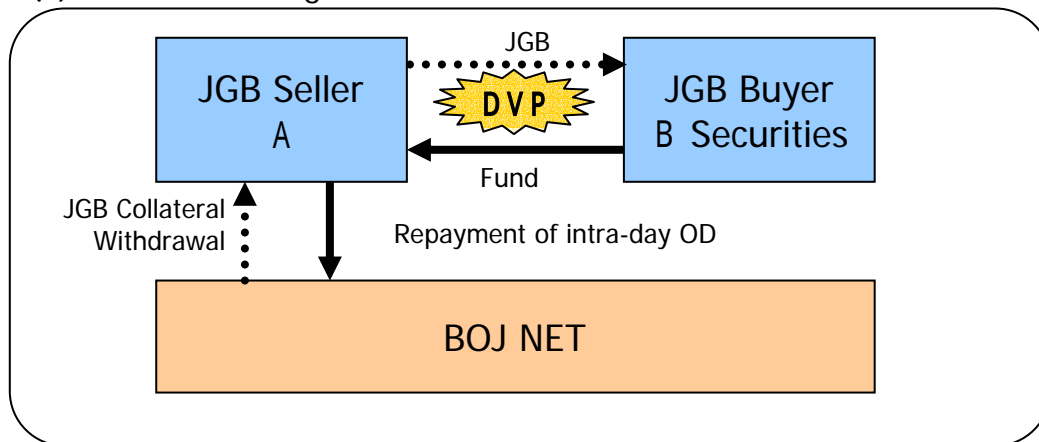



B - 2 - 4. Settlement Process (4/4)

- ITC (In-Transit Collateral) DVP (continued)

Flow of JGB ITC DVP Settlement

(1) When receiving JGBs (JGB Buyer - B Securities): settlement takes place in the order of the following

~

Deposit the received JGBs with BOJ as collateral

BOJ loans B Sec. intra-day OD

The funds received in are used to pay for the JGB purchase.

(2) When delivering JGBs (JGB Seller - A Bank): settlement take place in the order of the following ~

Withdraw the JGBs deposited as collateral

Deliver the JGBs to Buyer B Sec.

Use the funds received in to repay the intra-day OD

- The function can be utilized by a participant when necessary for regular trades between market financial institutions, for BOJ JGB Open Market Operation trade settlement, etc.
- When utilizing the function the participant has to use an exclusive settlement account for ITC DVP at BOJ.

The numbers in the above are corresponding to those on the previous page.



B - 3. Japan Bond Settlement Network

(JB NET)

- B - 3 - 1. Overview of System
- B - 3 - 2. Timetable for Settlement
- B - 3 - 3. Settlement Process

B - 3 - 1. Overview of System (1/2)

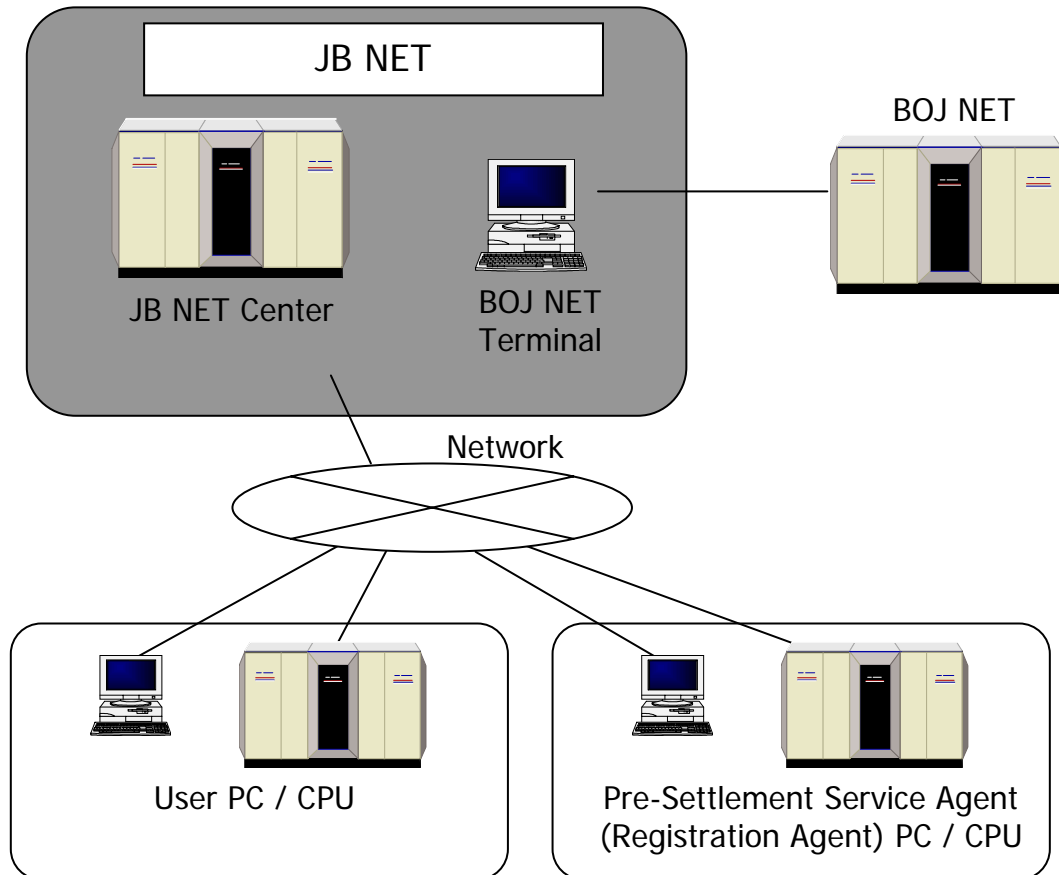

<Main Services>

Relay of information about
Registration Change Application,
Security Settlement, and Fund
Settlement of outstanding bond's
transfer trade

Relay of information about Initial
Registration Application of newly
issued bond's subscription trade
Inquiries related to the above
trades.

<Participants of the Network>

- Banks, etc. as Pre-settlement Service Agents (PSSA: Registration Agents)
... 37 companies
- User banks, securities houses, insurance companies, etc.
... 284 companies

(as of September, 2001)



B - 3 - 1. Overview of System (2/2)

<Fund Settlement Method>

Fund Settlement of bond trades through JB NET is done making use of the BOJ NET system. The method is as described below:

The information relating to the registration change application is sent to BOJ as fund settlement item data after the pre-settlement agent has examined the data.

BOJ informs the designated fund Payer and Receiver Participants thereof. The Payer's agent sends a payment instruction to BOJ, and the trade settles on pre-determined timing and net bases.

In other words, although JB NET does not do netting, net settlement is achieved by using BOJ NET.

<Method to Realize DVP>

As a counter-measure of settlement risk, securities are settled at a Pre-Settlement Service Agent (PSSA: Registration Agent) and, simultaneously, funds are settled at BOJ, and, accordingly, a DVP settlement is realized via JB NET.



B - 3 - 2. Timetable for Settlement

T	<ul style="list-style-type: none"> • Trade Executed
T+1	<ul style="list-style-type: none"> • Registration Change Application (User ---> Center) <ul style="list-style-type: none"> > Send Details of Registration Change Application (Center ---> PSSA) ... In total 4 times • Examination (PSSA) <ul style="list-style-type: none"> > Send Examination Result (Center ---> User) ... In total 8 times
T+2	<ul style="list-style-type: none"> • Balance Check, provide information on trade securities which are available to settle (by PSSA) <ul style="list-style-type: none"> 1st time ... 9:00 2nd time ... after 14:00 (until 15:45) • Send Fund Settlement Data (Center ---> BOJ) <ul style="list-style-type: none"> > Send Payment Request (BOJ ---> Fund Payer Participant) ... 16:00 • Payment Instruction (Fund Payer Participant ---> BOJ)
T+3	<ul style="list-style-type: none"> • Balance Check, provide information on trade securities which are available to settle (by PSSA) <ul style="list-style-type: none"> 3rd time ... after 12:00 (until 13:45) • Send Fund Settlement Data (Center ---> BOJ) <ul style="list-style-type: none"> > Send Payment Request (BOJ ---> Fund Payer Participant) ... request by request • Payment Instruction (Fund Payer Participant ---> BOJ) • Current A/C Settlement (BOJ) ... 15:00 • Security Settlement (Registration Agent) ... after 15:45



B - 3 - 3. Settlement Process (1/3) - Operational Flow

It can be said that the Registration Change Application related operational flow is the core service relating to fund settlement among those provided by JB NET. This operation includes the relay of information from a Registration Change Application through to the security transfer at the Pre-Settlement Service Agent (PSSA: Registration Agent) and the fund settlement at BOJ.

The operational flow of the registration change can be divided roughly into the following three phases:

Registration Change Application & Examination ... based on the trade contents, the Seller makes a Registration Change Application. PSSA (Registration Agent) examines the contents of the application.
Settlement Availability Information ... Based on the application, the PSSA checks the security transfer availability and sends the fund settlement data to BOJ. Also Pre-Advice of Settlement is given to the User.
DVP Settlement ... After informing BOJ of the fund settlement data, the funds are settled between Fund Payer and Receiver Participants in BOJ NET Current A/C System and the security is settled at Registration Agent (registration change) - DVP Settlement.

Flow of Data and Contents of Data will be described on the following pages:

B - 3 - 3. Settlement Process (2/3)

- Registration Change Application & Notice

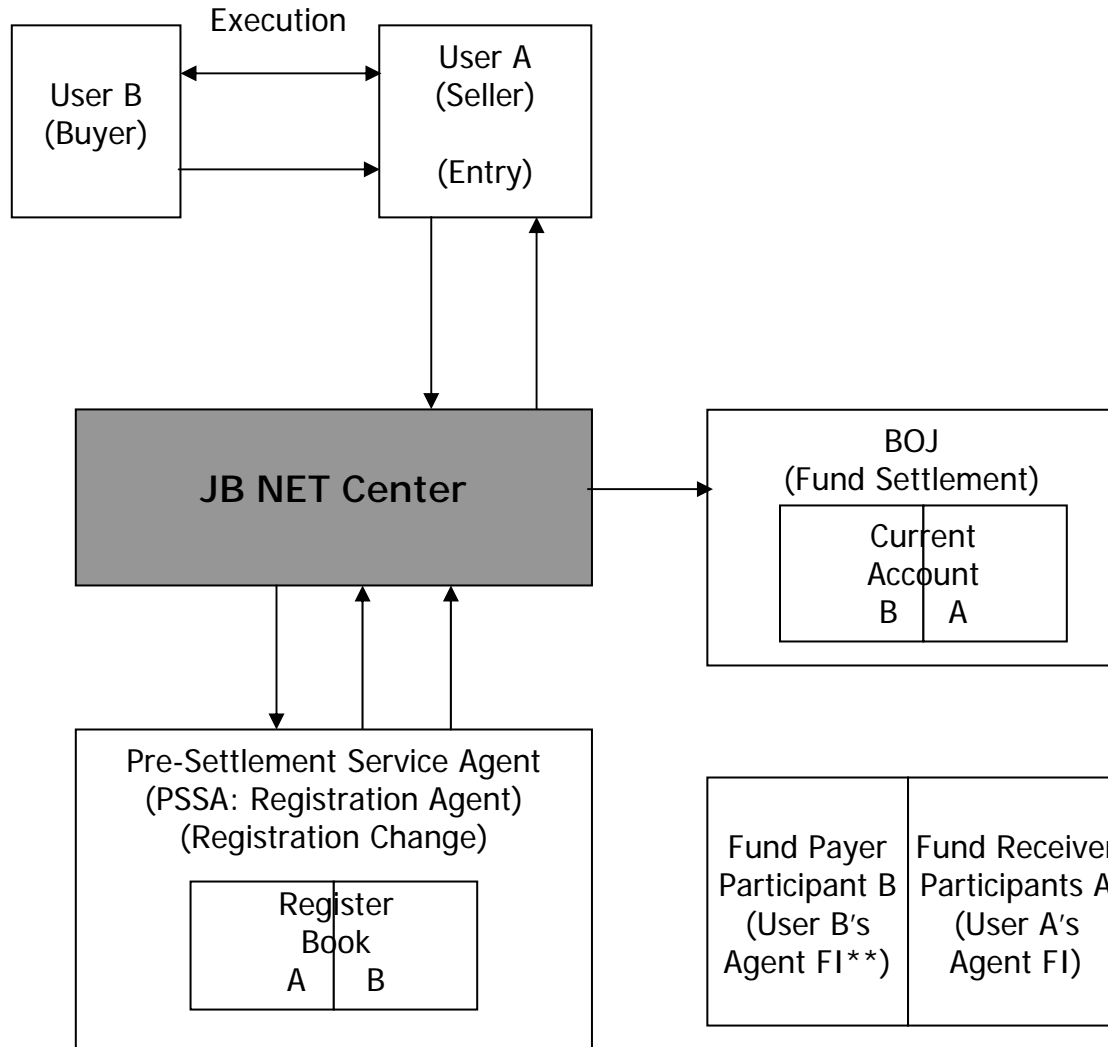

Creation and Sending of MAC (*)
Based on the trade contents User B (Buyer) produces a MAC and sends it to User A (Seller)

Registration Change Application (RCA)
User A (Seller) produces RCA.

Sending RCA Details
Send PSSA (Registration Agent) the RCA Details

Sending RCA Examination Result
PSSA examines the contents of RCA and sends the result to JB NET Center

Advice of RCA Exam. Result
Center sends User A (Seller) the RCA Exam. Result.

Sending Settlement Availability
PSSA checks position available to transfer (Balance Check) and notifies JB NET Center of the settlement availability.

Sending Fund Settlement Data
Sends BOJ the fund settlement data

(*) MAC: Message Authentication Code

(**) FI: Financial Institution

B - 3 - 3. Settlement Process (3/3)

- DVP Settlement

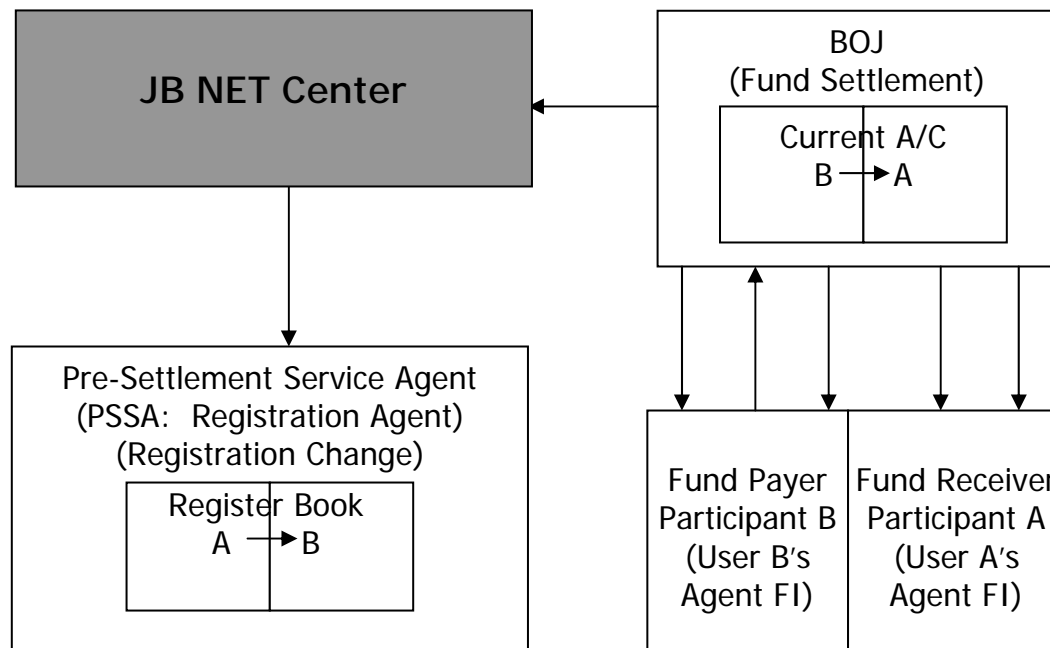
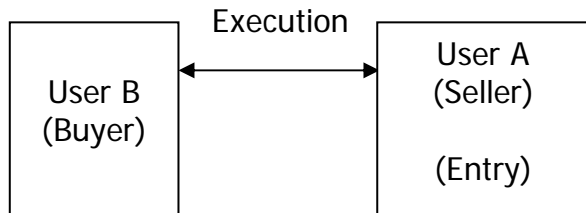

Sending Payment Request

Upon receipt of the Fund Settlement Data from JB NET Center, BOJ sends Payment Request to both Fund Receiver Participant A and Fund Payer Participant B.

Payment Instruction

Fund Payer Participant B sends Payment Instruction to BOJ.

The Fund Settlement is done in the BOJ Current A/C Settlement System.

Notice of Current A/C Jiten Kessai Completion

BOJ sends Notice of Current Account Jiten Kessai Completion to Fund Receiver Participant A and Fund Payer Participant B

3:00 p.m. Jiten Kessai Completion Advice
JB NET Center informs Registration Agent (PSSA) of the completion of 3:00 p.m. Jiten Kessai.

DVP Settlement

Registration Agent (PSSA) settles the security transfer (Registration Change)



B - 4. TSE (Tokyo Stock Exchange) DVP

- B - 4 - 1. Overview of System
- B - 4 - 2. Timetable for Settlement
- B - 4 - 3. Account Management
- B - 4 - 4. Settlement Process

B - 4 - 1. Overview of System

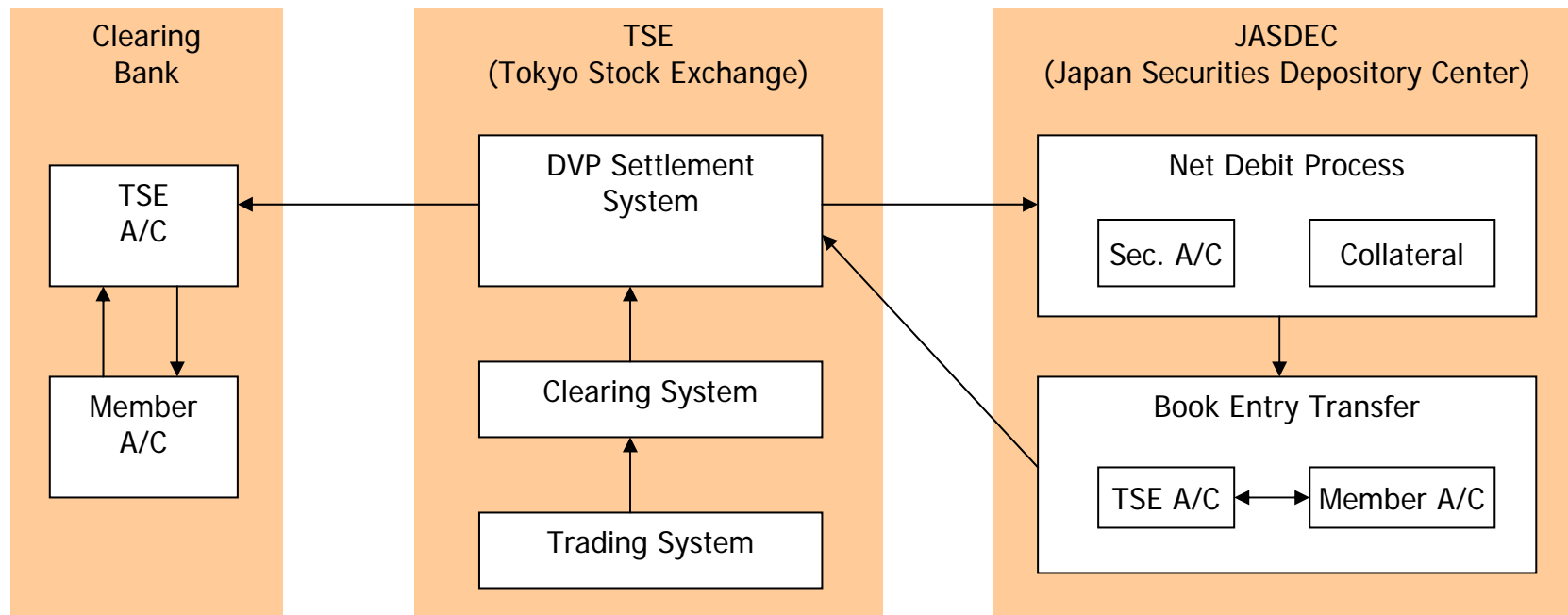

Trade Execution Data
 Clearing Data
 Netting resulting in creation of new Clearing /
 Settlement Information
 Fund Transfer Instruction
 Payment / Transfer of Cash Collateral
 Information of Payment / Cash Collateral

Net Debit Process
 Book Entry Transfer
 List of Unsettled DVP Settlement Items
 Fund Adjustment / Transfer Instruction
 Transfer

B - 4 - 2. Timetable for Settlement

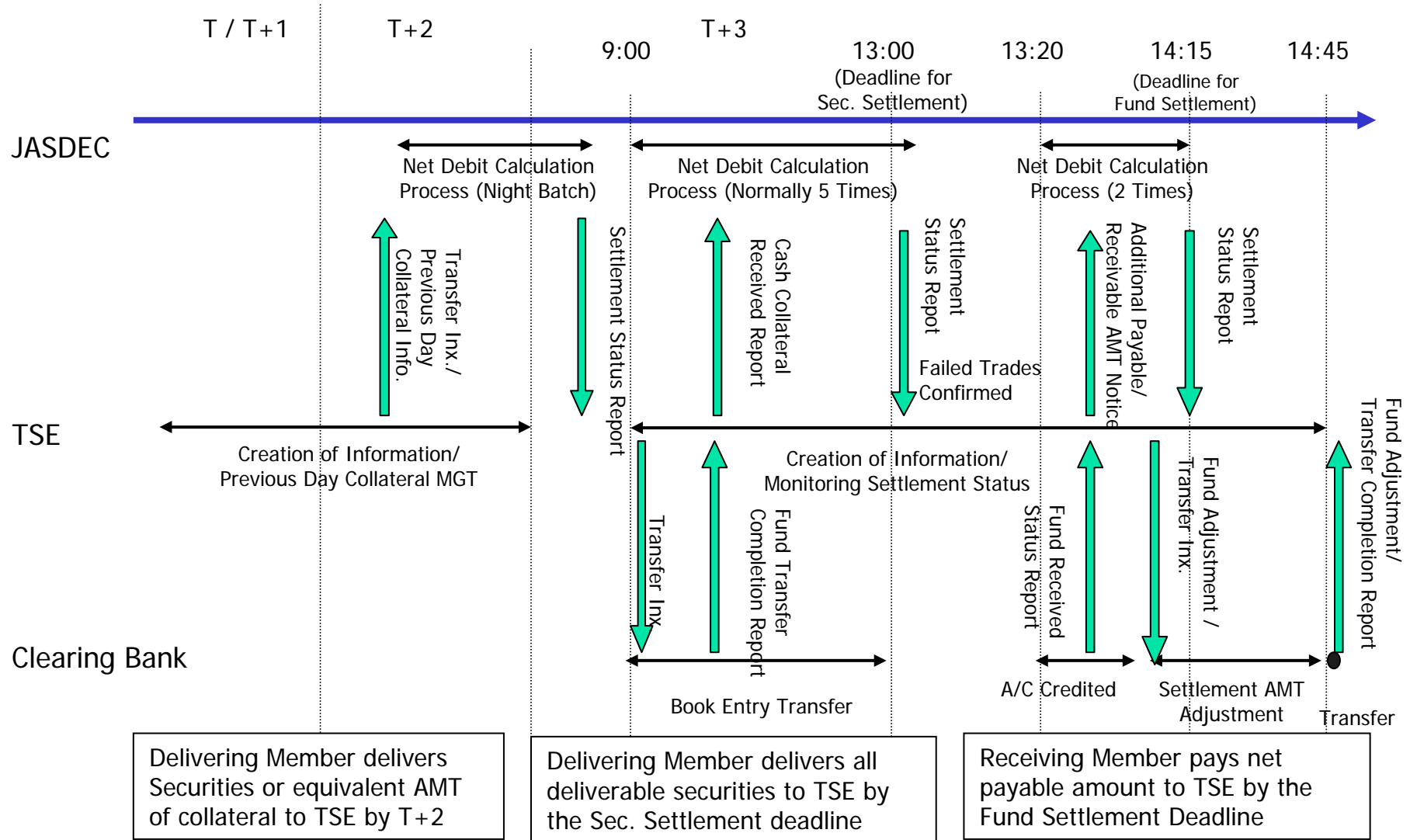

B - 4 - 3. Account Management (1/2)

- Clearing Bank

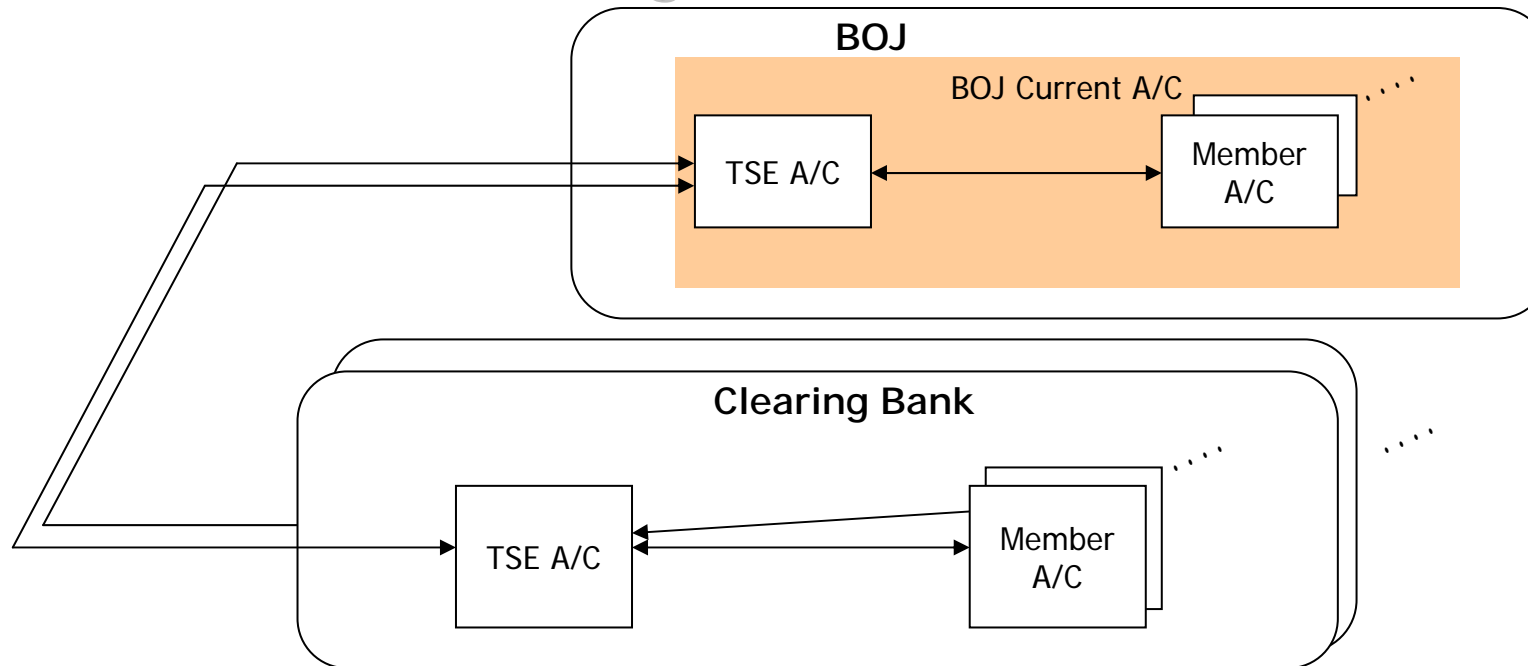

Clearing Bank

11 banks and BOJ are designated. Member selects one of them to settle funds by book entry transfer.

Member A/C

Member's Cash A/C where the member settles funds with TSE.

TSE A/C

Accounts that TSE has at the designated clearing banks through which the funds settlement of TSE DVP are done.

BOJ

One of clearing banks. Also fund balance adjustment between TSE accounts of the designated banks is done at BOJ

B - 4 - 3. Account Management (2/2)

- JASDEC (Japan Securities Depository Center)

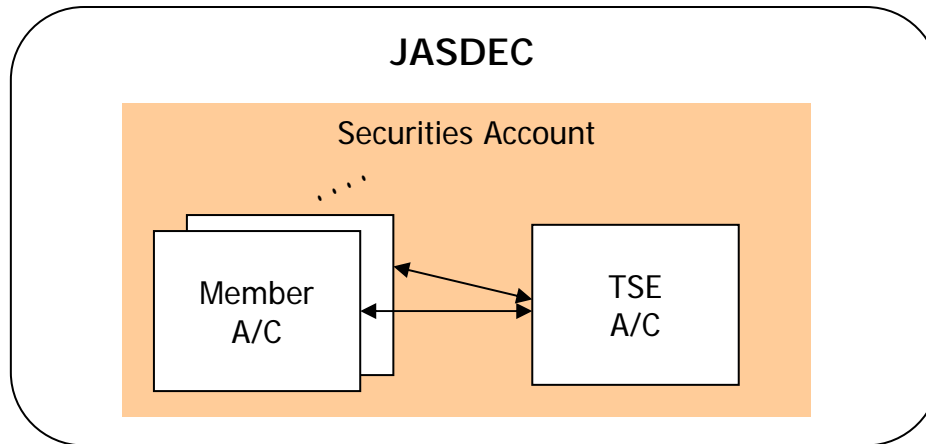

Participant A/C

JASDEC Participant's Securities A/C

TSE A/C

Security A/C that TSE has at JASDEC. Securities settlements of TSE DVP are all carried out through the TSE A/C

B - 4 - 4. Settlement Process

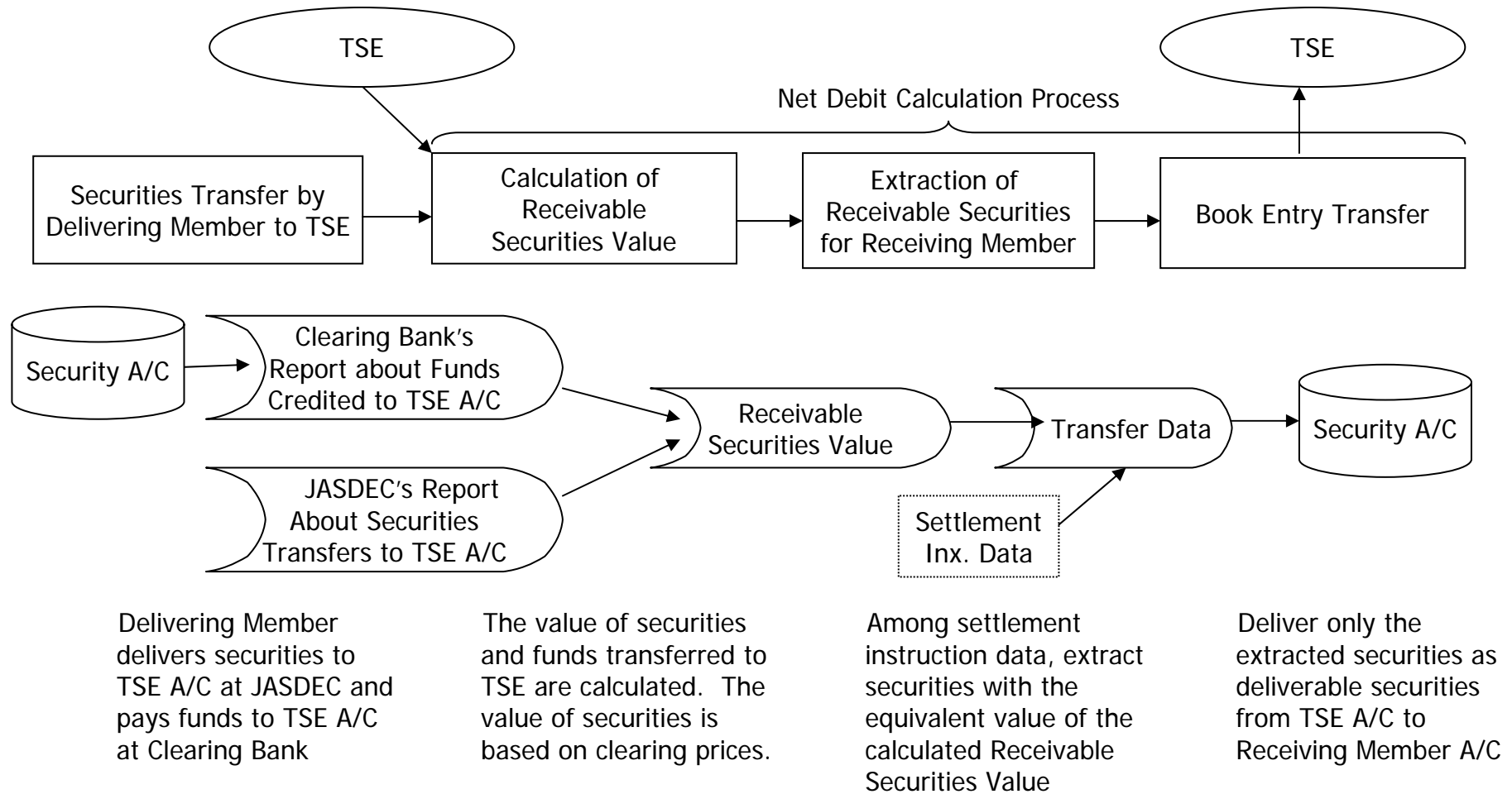



B - 5. CP Settlement System

(Pilot System)

- B - 5 - 1. Overview of System
- B - 5 - 2. Timetable for Settlement
- B - 5 - 3. Account Management
- B - 5 - 4. Settlement Process

B - 5 - 1. Overview of System (1/3)

- Issuance

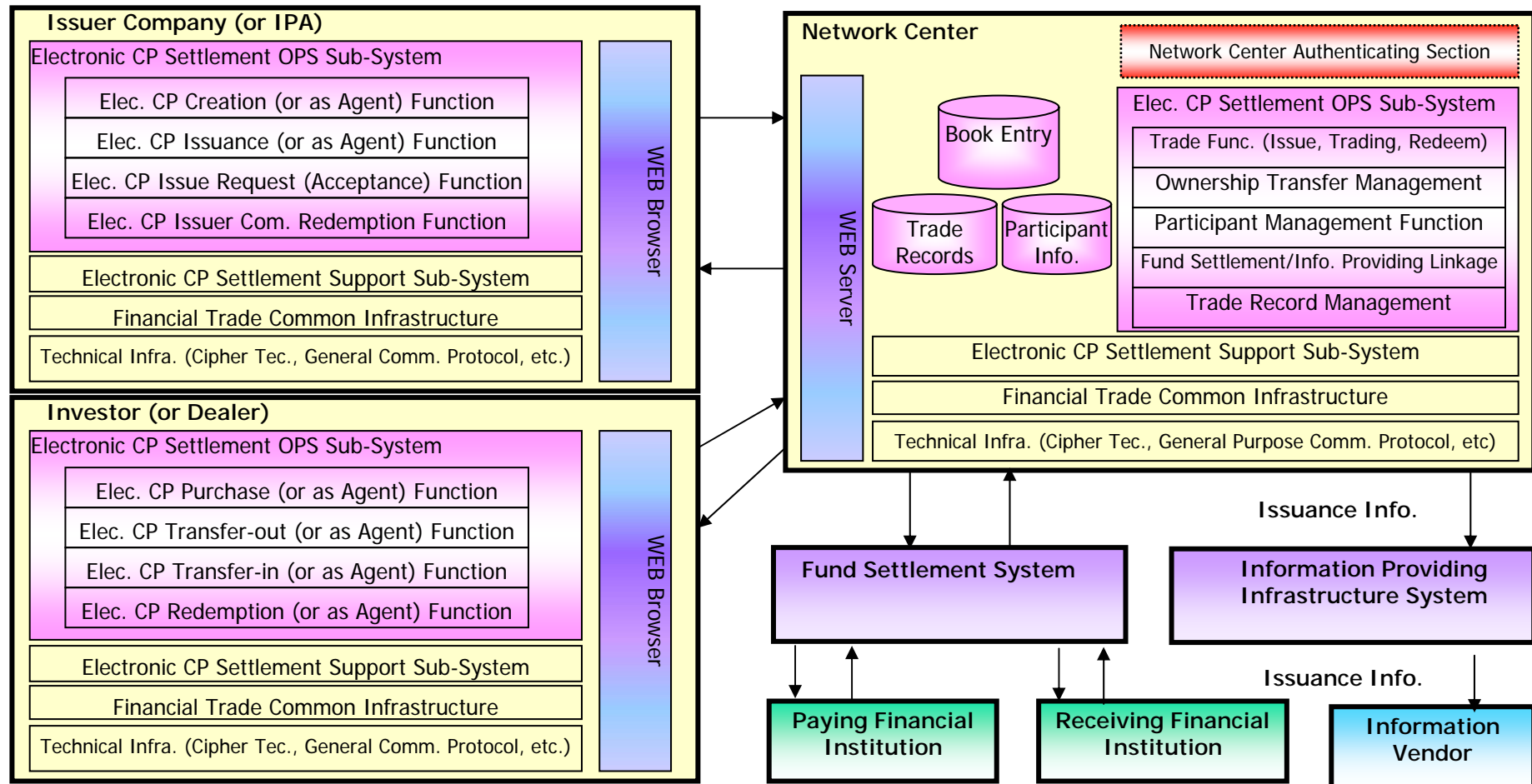

Issuer Com instructs to issue CP
 Inform Underwriter of issuance
 Underwriter confirms purchase

Instruct Fund Settlement on S/D
 Request Clearing Bank to settle
 Clearing Bank approves settlement

Notice of Fund Transfer Completion
 Record the transfer in Book Entry
 Inform the concerned of completion

B - 5 - 1. Overview of System (2/3)

- Secondary Trade

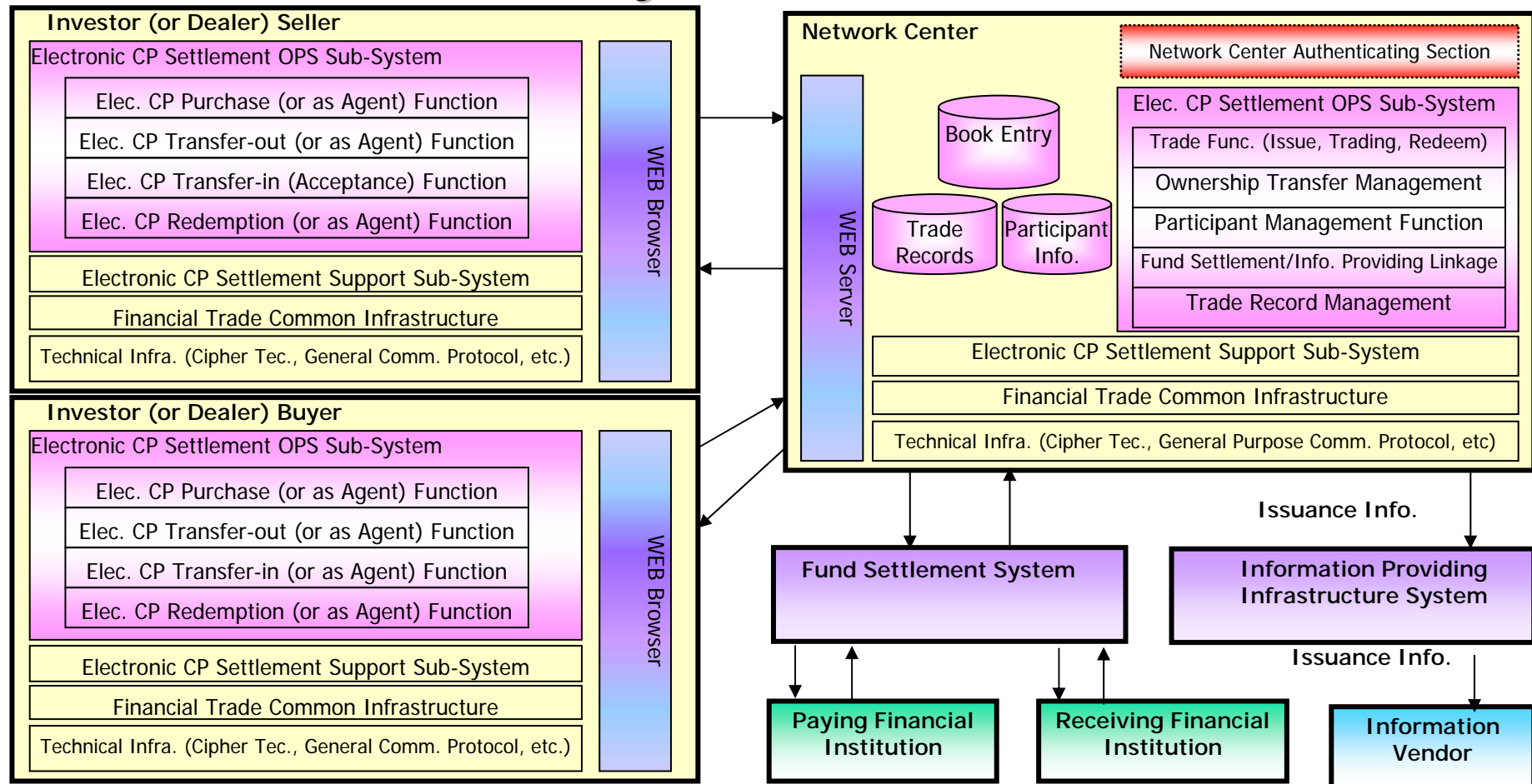

Holder informs of transfer-out of CP
 Informs Buyer of the transfer
 Buyer confirms of the purchase

Instruct Fund Settlement on S/D
 Request Clearing Bank to settle
 Clearing Bank approves settlement

Notice of Fund Transfer Completion
 Record the transfer in Book Entry
 Inform the concerned of completion

B - 5 - 1. Overview of System (3/3)

- Redemption

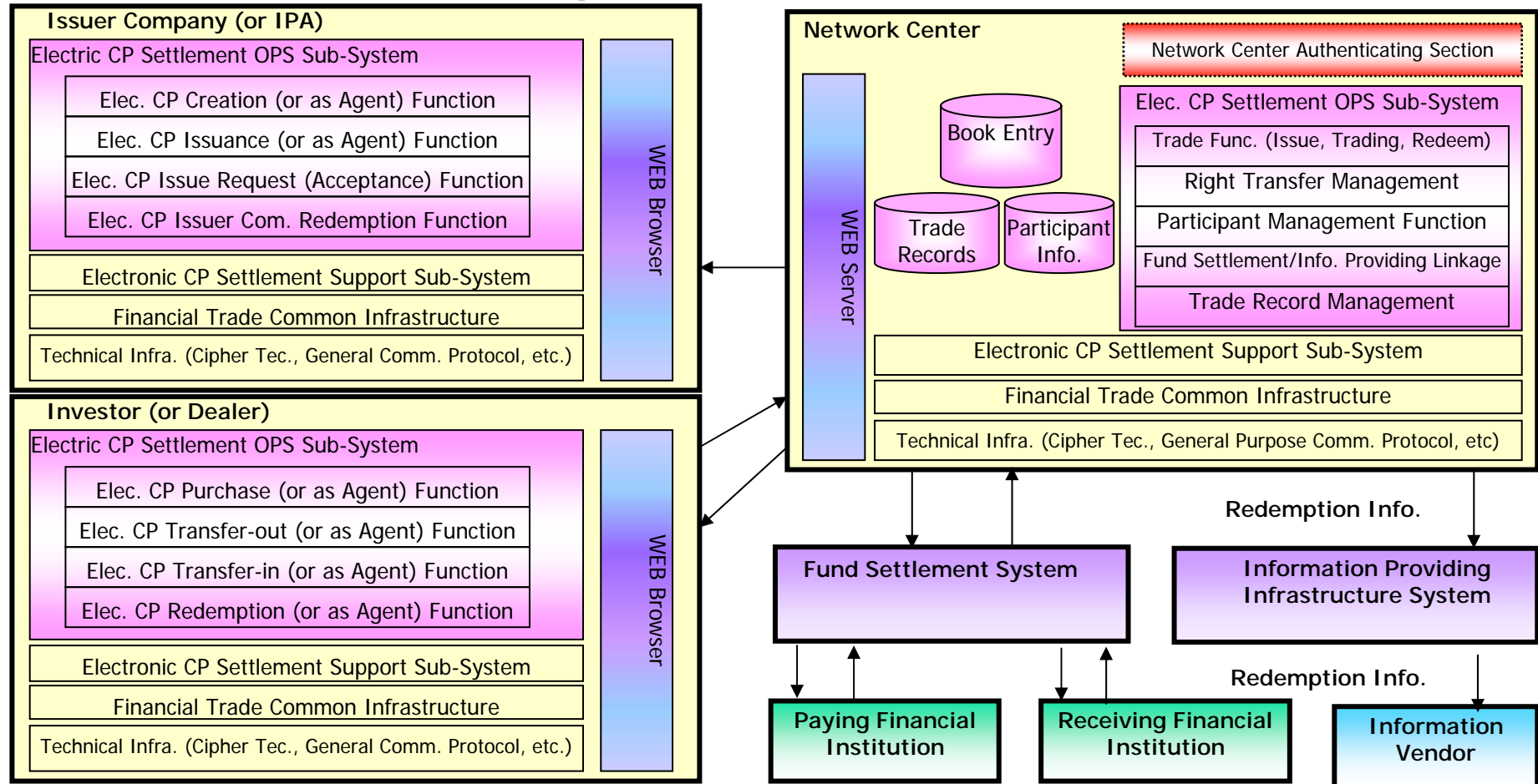

Holder advises of the redemption of CP
 Instruct Fund Settlement on R/D
 Request Clearing Bank to settle

Clearing Bank approves settlement
 Notice of Fund Transfer Completion
 Record the redemption in Book Entry

Inform the concerned of completion

B - 5 - 3. Account Management

Information about participants' rights are managed in the participants accounts in bulk.

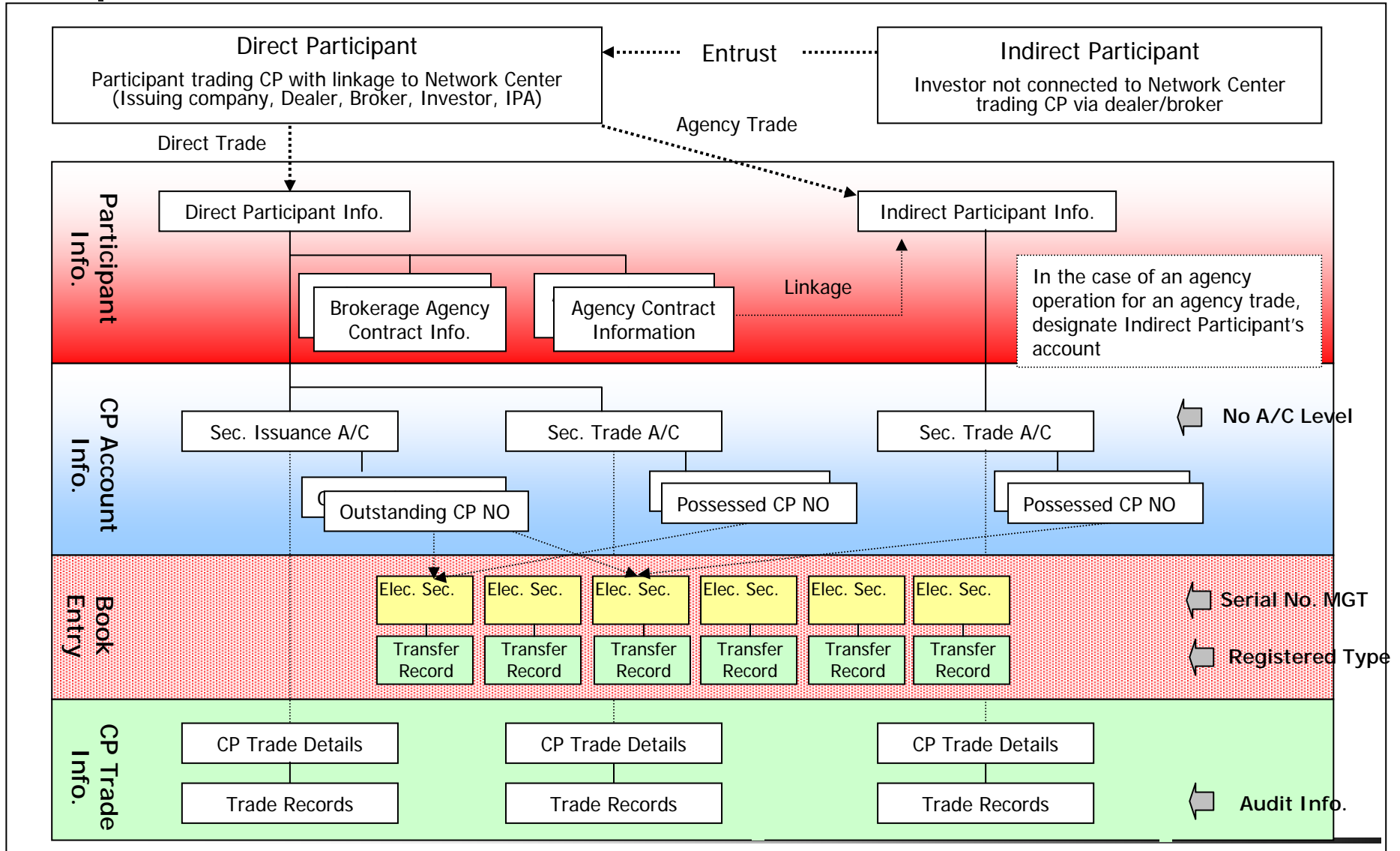

B - 5 - 4. Settlement Process

